



Meaningful Innovation.

WEEE Number: 80133970

# INSTRUCTION MANUAL

## SOLAR LED SPIKE LIGHT

### TECHNICAL DATA

MODEL	VT-1146
SKU	23015
LUMENS	90 Lm
SOLAR PANEL	DC 5.5V, 1.8W Polycrystalline
BATTERY	1800mAh, Li-Ion, DC: 3.7V
CHARGING TIME	8-10 Hours
WORKING TIME	6-8 Hours
BULB WATTS	2 W
COLOR TEMPERATURE	3000K
DIMENSION	155x155x200mm
MATERIAL	Aluminium+PC



**IP54  
RATING**

**03  
YEAR  
WARRANTY\***

### INTRODUCTION & WARRANTY

Thank you for selecting and buying V-TAC product. V-TAC will serve you the best. Please read these instructions carefully before starting the installation and keep this manual handy for future reference. If you have any another query, please contact our dealer or local vendor from whom you have purchased the product. They are trained and ready to serve you at the best. The warranty is valid for 3 years from the date of purchase. The warranty does not apply to damage caused by incorrect installation or abnormal wear and tear. The company gives no warranty against damage to any surface due to incorrect removal and installation of the product. The products are suitable for 10-12 Hours Daily operation. Usage of product for 24 Hours a day would void the warranty. This product is warranted for manufacturing defects only.

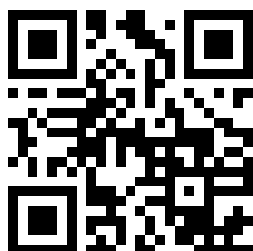

#### MULTI-LANGUAGE MANUAL QR CODE

Please scan the QR code to access the manual in multiple languages.

In case of any query/issue with the product, please reach out to us at: [support@v-tac.eu](mailto:support@v-tac.eu)  
For More products range, inquiry please contact our distributor or nearest dealers.  
V-TAC EUROPE LTD. Bulgaria, Plovdiv 4000, bul.L.Karavelow 9B

## **WARNING**

1. Please make sure to turn off the power before starting the installation.
2. Installation should be done by certified electrician.
3. The light source of this luminaire is not replaceable; when the light source reaches its end of life the whole luminaire shall be replaced.



This marking indicates that this product should not be disposed of with other household wastes.

## **INSTALLATION DIAGRAM**

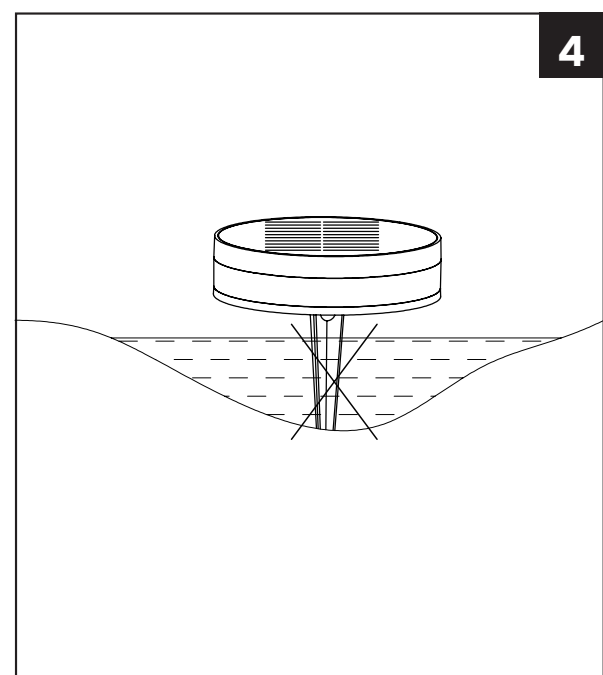
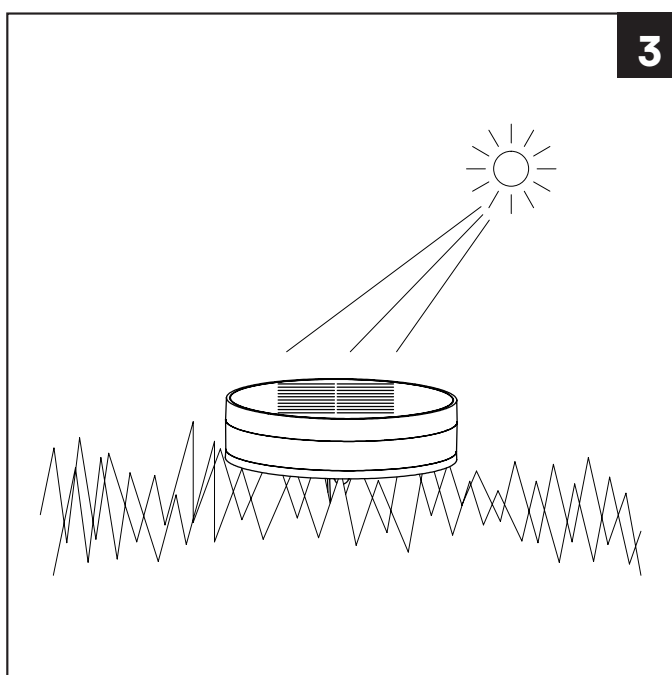
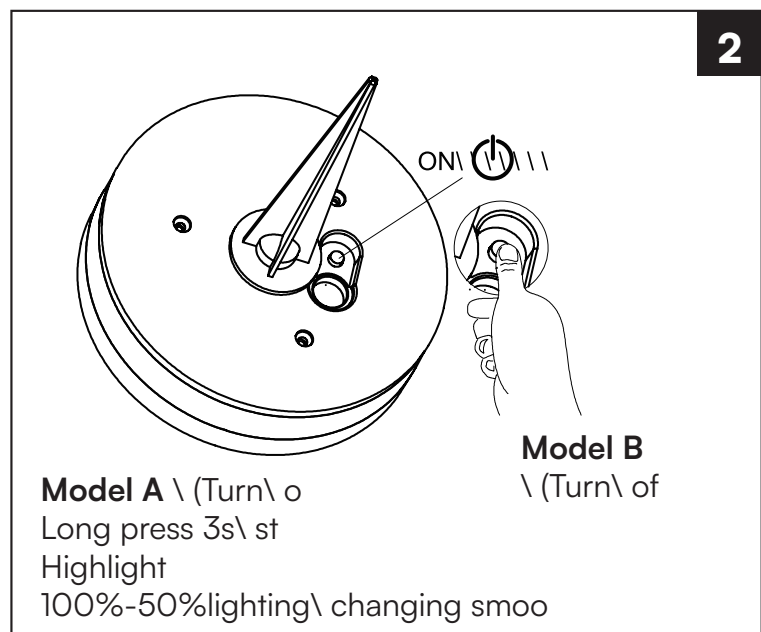
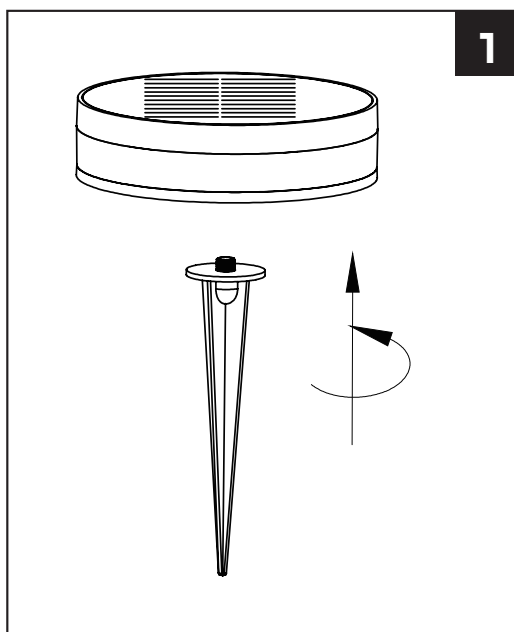

---

## **INSTALLATION INSTRUCTION**

1. Fix the spike with body
2. Turn on the switch and test

## **MAINTENANCE & WARNING**

- Do not use solvents, petrol, etc. Otherwise the light will be damaged.
- Clean the light with a dry, lint-free cloth.
- Check the solar panel for dirt regularly. If dirt or is present remove it to guarantee flawless function of the product.
- Especially during the winter, keep the product free from snow and ice.
- Confirm installation direction is correct (solar panel should be at top).
- Confirm no objects blocking the solar panel to receive sunlight.
- Keep away from the fire.
- Don't immerse in the water

RoHS



UK  
CA

